

铆M5螺母

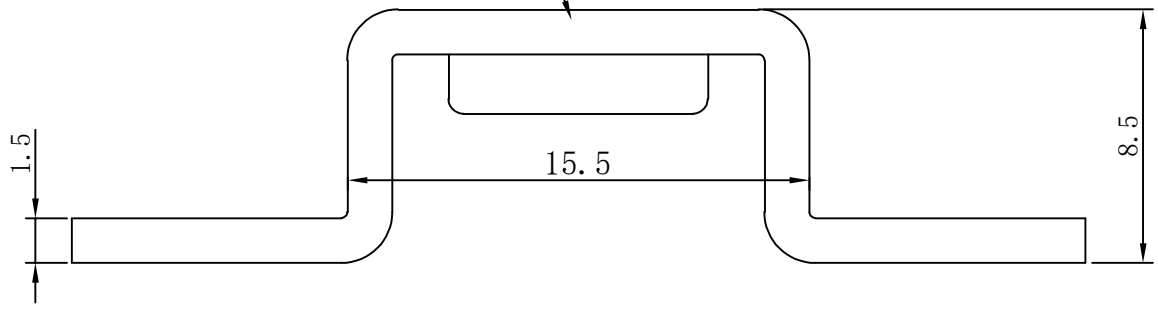

- 技术要求:
- 1.打铜底0.5-1 μ m,镍1-2.5 μ m, 镀锡3-5 μ m。
 - 2.铆好后不得有松动现象。
 - 3.插脚尖部符合可焊性要求。
 - 4.螺纹需符合通止规/止针要求。
 - 5.螺纹扭矩: 2.0Nm.
 - 6.额定电流: 100A.

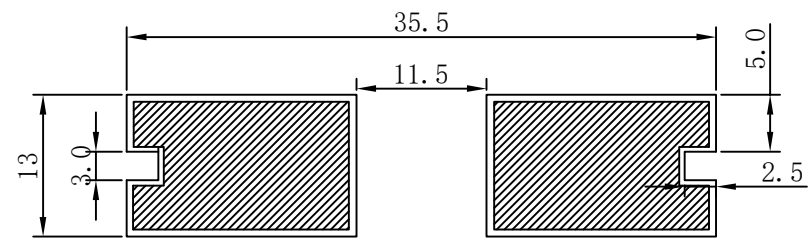
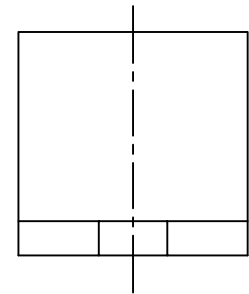
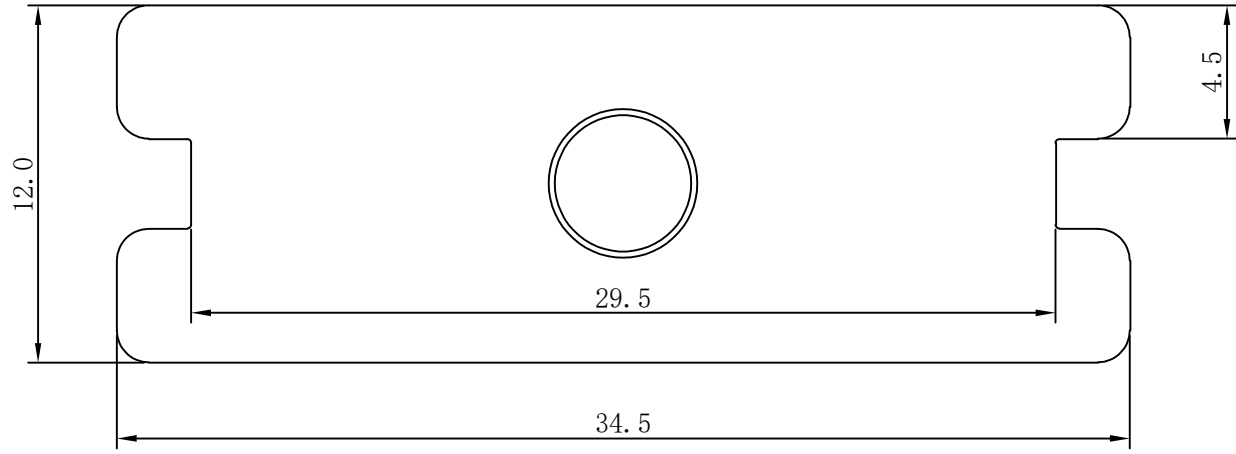

PCB LAYOUT

2	螺母		SPCC	1
1	插脚		H62(Y2)	1
序号	名称	零件编号	材质	数量

KQSYCN
 www.kqsycn.com 科晴实业
 400-092-6568

THIS DRAWING AND ANY INFORMATION OR DESCRIPTIVE MATTER SET OUT HEREON ARE CONFIDENTIAL AND COPYRIGHT PROPERTY OF KQSYCN AND MUST NOT BE DISCLOSED, LOANED, COPIED OR USED FOR MANUFACTURING, TENDERING OR FOR ANY OTHER PURPOSE WITHOUT THEIR WRITTEN PERMISSION.

TOLERANCES

>60	±0.60
30-60	±0.45
06-30	±0.35
0-6	±0.25
ANGLES	±1°

VIEW	
UNITS	mm
REV	A1
SHEET	1/1
DATE	2025.09.15

TITLE:
 PCB SOLDERING TERMINAL
 PART NO:
 KQ-M515-4J085

APPD	Li Jian
CHKD	Wan Yong
DRAW	Wan Yong